



KIT PART NUMBER 6230110

INSTRUCTIONS FOR INSTALLING A HEATER TERMINAL REPLACEMENT KIT IN A HOT DRINK CENTER

CHECK THE PARTS RECEIVED IN THE KIT WITH THE PARTS LIST IN THESE INSTRUCTIONS. IF ANY PARTS ARE MISSING, CONTACT THE NATIONAL VENDORS PARTS DEPARTMENT IMMEDIATELY.

Read these instructions carefully before installing the kit.
Keep these instructions for part numbers and for future reference.

This kit contains the following:

INDEX	PART NUMBER	DESCRIPTION	QUANTITY
1	6339018	JUMPER - HEATER TERMINAL F/X	1
2	6338022	INSULATION - WATER HEATER	1
3	6238104	COVER - HEATER - WATER TANK	1

WARNING

Lethal voltages are present. Be sure to remove power from the merchandiser before performing the following steps.

1. Turn the main power switch OFF. If possible, unplug the merchandiser.
2. Gain access to the water tank heater terminals by removing the cover and insulator. Discard the cover and insulator.
3. Unplug the harness from the heater and cut the wires to length as shown in figure 1 (you will have to remove the harness from the wire clamp to do this).

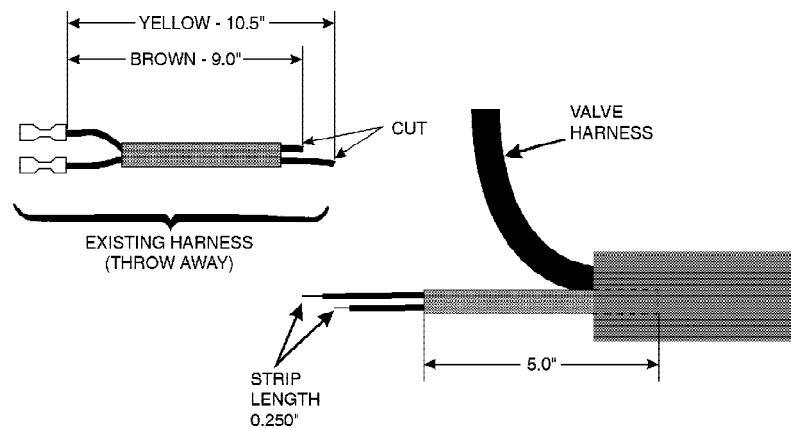

Figure 1



4. See figure 2. Splice the new jumper (6339018) to the brown and yellow wires.
5. Slide the jumper wire cover over the harness cover to conceal the splices as shown.

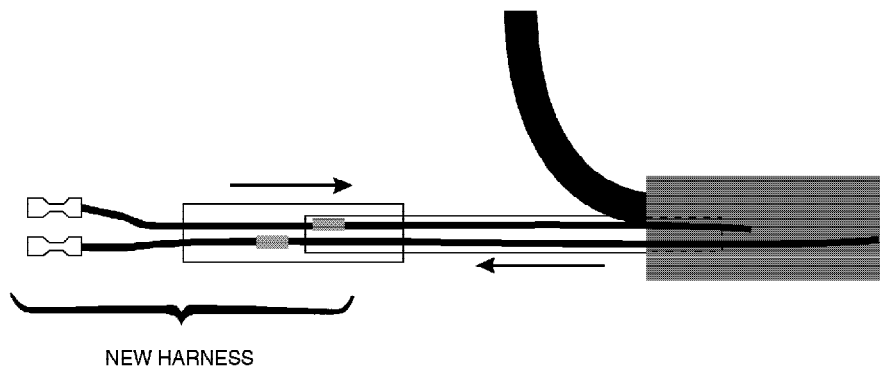

Figure 2

6. See figure 3. Connect the harness to the heater.
7. Place the harness in the wire clamp as shown.
8. Place the new insulator over the top two studs as shown.
9. Install and secure the new terminal cover. **NOTE:** The harness wire cover should be under the terminal cover so that no wires are exposed.
10. Restore power to the machine.

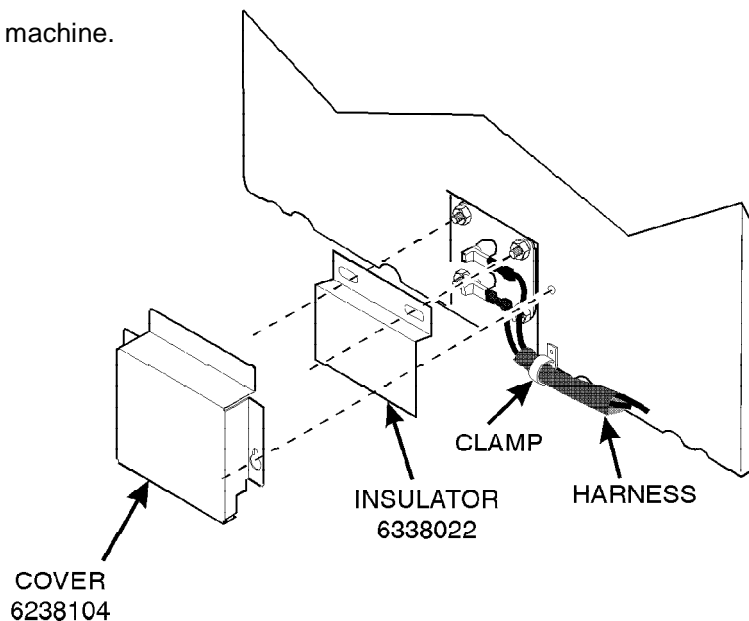

Figure 3